

# Unique PB Pin Bush Couplings

For Compensating misalignment, shock & vibration

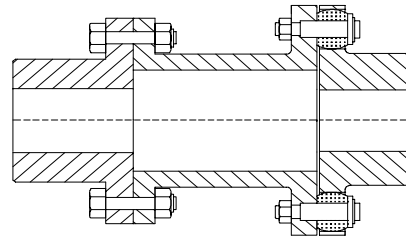

Spacer Coupling

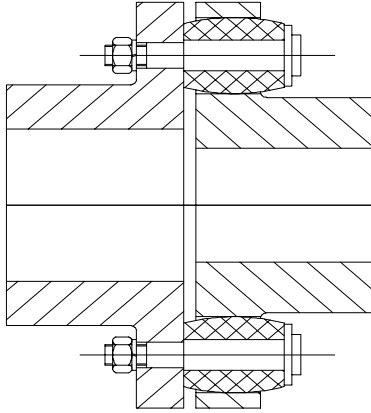
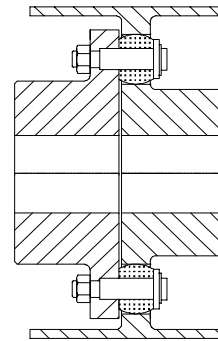

Brake Drum Coupling

- \*\*\*Unique PB Pin Bush Couplings are used in General Engineering applications for reliable power transmission under normal shaft misalignments.
- \*\*\* Couplings dampen shocks and vibrations
- \*\*\* Progressively increasing stiffness characteristics of special shaped buffers ensure control of vibration amplitude for protection of equipment.
- \*\*\* Couplings can take considerable overloads.
- \*\*\* Standard range has hubs of Cast Iron
- \*\*\* For special applications couplings with forged steel hubs available.
- \*\*\* Also available couplings with Brake Drum Couplings with spacer.

Special barrel shaped buffers provide superior torsional resilience.

Deformation of baredled buffer with increasing loads

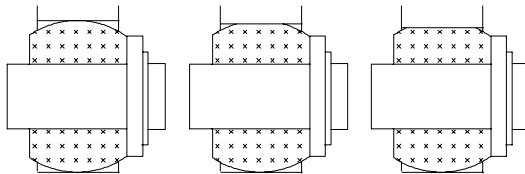

Light

Normal

Shock

## Unique Transmission (India) Pvt Ltd.

Head Off 10/ID Lal Bazar Street ,Calcutta 700001

Tel No - 91-33- 2200366,24 Fax -91-33- 2206593

Email - metaflex@vsnl.com ; couplings@vsnl.com

Branch Office - 35/36 Nehru Place N.Delhi , Tel 91-11-6422983

**Unique PB Flexible Pin Bush Coupling in standard design  
With Cast Iron Hubs**

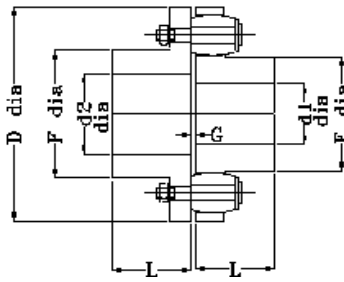

**SIZES 96 TO 400**

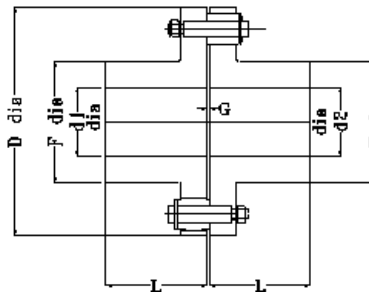

**SIZES 450 ONWARDS**

SIZE	NO OF PINS	RATING		MAX SPEED RPM	MAX BORE		D DIA	E	F	L	G
		TORQUE NM	HP/100 RPM		d1 MM	d2 MM					
96	8	125	1.75	7200	28	30	96	44	50	35	4
112	10	250	3.5	6100	38	42	112	62	68	45	4
125	8	400	5.6	5500	40	48	125	65	75	50	4
140	10	520	7.3	4900	48	55	140	76	88	55	4
160	9	750	10.5	4500	55	60	160	85	95	60	4
180	10	1050	14.7	3800	65	70	180	102	112	70	4
200	12	1450	20.3	3400	75	80	200	120	128	80	4
225	11	2400	33.7	3000	85	90	225	134	144	90	7
250	12	3000	42.1	2700	95	105	250	154	164	100	7
285	11	4900	68.8	2400	105	110	285	166	176	110	7
320	12	6000	84	2100	120	125	320	190	195	125	7
360	11	10000	140	1900	130	135	360	205	210	140	10
400	10	14000	196	1700	135	145	400	218	230	160	10
450	12	21000	295	1500	160	160	450	255	255	180	6
500	14	27500	385	1350	180	180	500	290	290	200	6
560	10	33100	465	1200	200	200	560	320	320	220	6
630A	12	46000	645	1050	160	160	630	300	300	240	6
630B	12	46000	645	1050	220	220	630	355	355	240	6
710A	12	80000	1122	950	180	180	710	350	350	290	7
710B	12	80000	1122	950	240	240	710	400	400	290	7
800A	14	110000	1543	850	220	220	800	420	420	290	7
800B	14	110000	1543	850	260	260	800	460	460	290	7
800C	14	110000	1543	850	290	290	800	490	490	290	7
900A	16	190000	2666	750	250	250	900	470	470	340	7
900B	16	190000	2666	750	300	300	900	515	515	340	7
900C	16	190000	2666	750	340	340	900	560	560	340	7
1000A	18	250000	3508	675	275	275	1000	480	480	400	10
1000B	18	250000	3508	675	320	320	1000	530	530	400	10
1000C	18	250000	3508	675	380	380	1000	590	590	400	10
1100A	16	320000	4490	615	300	300	1100	540	540	440	10
1100B	16	320000	4490	615	350	350	1100	595	595	440	10
1100C	16	320000	4490	615	400	400	1100	650	650	440	10
1200A	18	400000	5613	560	300	300	1200	570	570	480	10
1200B	18	400000	5613	560	375	375	1200	640	640	480	10
1200C	18	400000	5613	560	450	450	1200	720	720	480	10

Note : Standard Construction with Cast Iron Hubs

Larger Bore capacities can be offered with steel hubs / hubs of special design

Higher speeds with steel hubs can be offered on request

**Unique Transmission ( India) Pvt. Ltd.**

Head Off 10/1D Lalbazar Street ,Calcutta 700001:Fax:91-33-2206593 :Phone :2200366,2480231,2480433  
Branch Off 35-36 Nehru Place ,2nd Floor ,N.Delhi -110019: Phone - 91-11-6422983 FAX 6472188

## Selection Procedure Unique Pin Bush Coupling

Step 1- Tentatively select coupling considering driving & driven shaft dia

Step 2- Determine required HP/100 RPM rating as follows :

$$\text{Required HP/100 rpm} = P \cdot 100 \cdot \text{SF} / N$$

Where P is primemover Power in HP , SF is service factor

N is operating RPM

Step 3 – if selected coupling by step 1 has HP/100 RPM > required HP/100 rpm , selection is OK . Otherwise select higher size coupling with adequate HP/100 rpm rating.

Step 4 – finally check operating rpm is less than maximum permissible rpm.

Service Factors

Duty		Type of Prime Mover		
Load	Driven Equipment	Motor/ turbine	Hydraulic	Recipro- cating engine
Uniform	Centrifugal Pumps - uniform load Conveyors-uniform load , Fans & Blowers- light duty, Exciters , Generators- uniform load , Mixers-liquid	1.0	1.25	1.50
Light Shock	Centrifugal pimps – pulsating loads Generators- pulsating load, kilns Grinders , Hydraulic Pumps , Line Shafting , Machine tools , Textile Machinery	1.50	1.75	2.0
Medium Shock	Rec. Air Compressors- multi cylinder Ball & Rod Mills , Cranes , Elevators , Hoists , Punch Press, REC Pumps , Shears ,Deck Machinery , Welding Generator	2.0	2.25	2.5
Heavy Shock	Air Compressor – 1 cylinder , Dredges ,Drilling rigs , Mine Machinery , Rolling Mill Drive , Rubber Mixer	2.5	2.75	3.0
Extreme Shock	Ore Crushers , Vibrating Conveyors , Bar stock Shear	3.0	3.5	4.0

Couplings can accept infrequent 3 times rated nominal torque for short duration such as starting. Starting torque need not be considered for selection for normal application. However where starting/ stopping is very frequent appropriate service factor should be considered depending on figures of torque peaks.

For speeds less than 100 RPM , Service factors may be reduced – Consult Unique

Unique Transmission (India) Pvt Ltd

Page 3

## Unique PB Flexible Pin Bush Coupling in special design With Steel Hubs

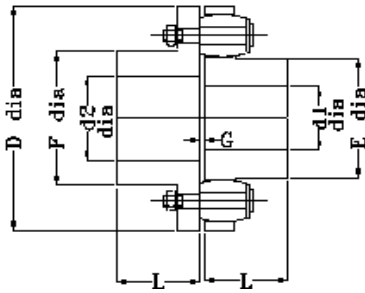

**SIZES 96 TO 400**

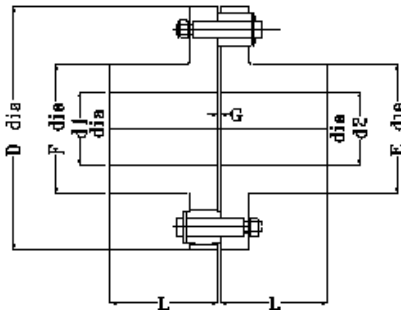

**SIZES 450 ONWARDS**

SIZE	NO OF PINS	RATING		MAX SPEED RPM	MAX BORE		D DIA	E	F	L	G
		TORQUE NM	HP/100 RPM		d1 DIA MM	d2 DIA MM					
96	8	125	1.75	7800	30	35	96	44	50	35	4
112	10	250	3.5	7200	43	48	112	62	68	45	4
125	8	400	5.6	6600	45	50	125	65	75	50	4
140	10	520	7.3	6000	53	60	140	76	88	55	4
160	9	750	10.5	5300	60	65	160	85	95	60	4
180	10	1050	14.7	4900	70	75	180	102	112	70	4
200	12	1450	20.3	4600	85	90	200	120	128	80	4
225	11	2400	33.7	4400	90	100	225	134	144	90	7
250	12	3000	42.1	4200	105	115	250	154	164	100	7
285	11	4900	68.6	3900	115	120	285	166	176	110	7
320	12	6000	84	3500	130	135	320	190	195	125	7
360	11	10000	140	3100	145	150	360	205	210	140	10
400	10	14000	196	2800	150	160	400	218	230	160	10
450	12	21000	295	2500	180	180	450	255	255	180	6
500	14	27500	385	2200	200	200	500	290	290	200	6
560	10	33100	465	2000	225	225	560	320	320	220	6
630A	12	46000	645	1800	200	200	630	300	300	240	6
630B	12	46000	645	1800	250	250	630	355	355	240	6
710A	12	80000	1122	1600	240	240	710	350	350	290	7
710B	12	80000	1122	1600	280	280	710	400	400	290	7
800A	14	110000	1543	1400	280	280	800	420	420	290	7
800B	14	110000	1543	1400	320	320	800	460	460	290	7
800C	14	110000	1543	1400	340	340	800	490	490	290	7
900A	16	190000	2666	1240	315	315	900	470	470	340	7
900B	16	190000	2666	1240	360	360	900	515	515	340	7
900C	16	190000	2666	1240	390	390	900	560	560	340	7
1000A	18	250000	3508	1110	310	310	1000	480	480	400	10
1000B	18	250000	3508	1110	360	360	1000	530	530	400	10
1000C	18	250000	3508	1110	410	410	1000	590	590	400	10
1100A	16	320000	4490	1000	370	370	1100	540	540	440	10
1100B	16	320000	4490	1000	400	400	1100	595	595	440	10
1100C	16	320000	4490	1000	450	450	1100	650	650	440	10
1200A	18	400000	5613	915	390	390	1200	570	570	480	10
1200B	18	400000	5613	915	440	440	1200	640	640	480	10
1200C	18	400000	5613	915	500	500	1200	720	720	480	10

### Unique Transmission ( India) Pvt. Ltd.

Head Off 10/1D Lalbazar Street ,Calcutta 700001:Fax:91-33-2206593 :Phone :2200366,2480231,2480433  
Branch Off 35-36 Nehru Place ,2nd Floor ,N.Delhi -110019: Phone - 91-11-6422983 FAX 6472188

## Unique PB Pin Bush Coupling

### Engineering Data

Size	Weight Kg	Inertia MR <sup>2</sup> Kg.m <sup>2</sup>	Max Misalignment		
			Axial + -	Radial + -	Angular Degree
96	1.5	0.002	2	0.3	1
112	2.5	0.003	2	0.3	1
125	3.5	0.006	2	0.4	1
140	4.7	0.010	2	0.4	1
160	6.8	0.020	2	0.5	1
180	9.7	0.034	2	0.5	1
200	14	0.057	3	0.5	1
225	20	0.11	3	0.6	1
250	27	0.18	3	0.6	1
285	40	0.36	3	0.7	1
320	53	0.59	4	0.7	1
360	76	0.96	4	0.9	1
400	113	2.0	2	1.1	1
450	157	3.5	2	1.1	0.5
500	212	5.6	2	1.1	0.4
560	304	10.6	2	1.5	0.3
630A	394	15.9	2	1.5	0.3
630B	402	17.3	2	1.5	0.3
710A	647	33.5	2	1.8	0.3
710B	649	35.5	2	1.8	0.3
800A	850	55.8	2	1.8	0.3
800B	866	58.6	2	1.8	0.3
800C	876	61.2	2	1.8	0.3
900A	1224	100.9	2	1.8	0.3
900B	1236	106.1	2	1.8	0.3
900C	1266	112.9	2	1.8	0.3
1000A	1518	151.6	3	1.8	0.3
1000B	1566	159.8	3	1.8	0.3
1000C	1600	171.4	3	1.8	0.3
1100A	2135	258.6	3	1.8	0.3
1100B	2195	272.2	3	1.8	0.3
1100C	2253	289.2	3	1.8	0.3
1200A	2664	369.1	3	1.8	0.3
1200B	2730	392.3	3	1.8	0.3
1200C	2830	428.7	3	1.8	3

Weights and Inertia are at max Bore.

The figures of misalignment are maximum values. It is advisable to align shafts as accurately as practical for long life of bushes.

**Unique Transmission (India) Pvt Ltd**

# Unique Transmission India Pvt Ltd.

## Installation & Maintenance of Unique PB PINBUSH Couplings.

**1-General** - Correct Installation of Unique PB Pin Bush Couplings goes a long way in ensuring satisfactory performance. The following instructions should be followed. Flexible Element (Rubber Bush) is made of rubber reinforced and gives flexibility in all directions. Normally only Rubber bushes & Pins may require replacement. Rubber Bush must be protected against dripping oil and against radiation of heat. The bush is fit for ambient temperatures -30 deg C to 60 deg C. The coupling is supplied duly assembled.

### **2.Installation –**

1. All components should be cleaned thoroughly. Particular attention should be paid to removal of any protective coating in the bore of hubs. The hubs should be bored true to outer dia and accurately as per shaft sizes.

2-. Fit Hubs . Do not hammer in hubs – if necessary hubs may be heated in Oil upto temperature 200 deg C. Hubs should be normally fitted flush with shaft ends. However shaft can remain inside hubs provided enough length is covered by hubs.

3. The shaft with hubs duly mounted must be aligned properly, care being taken that gap between hubs is within the limits stated in catalogue.

5. Check the parallel alignment and angular alignment by dial gauge To achieve required alignment, necessary shifting/shimming under the equipment may be done.

It is recommended that TIR ( Total indicator reading) & gap between hubs be within these limits.

Size	Parallel TIR max mm	Angular TIR max mm	Gap between hubs ,mm	Size	Parallel TIR max mm	Angular TIR max mm	Gap between hubs mm
PB96	0.075	0.10	4+ - 2	PB320	0.175	0.25	7+ - 3
PB112	0.075	0.10	4+ - 2	PB360	0.225	0.30	10+ - 4
PB125	0.100	0.15	4+ - 2	PB400	0.250	0.30	10+ - 4
PB140	0.100	0.15	4+ - 2	PB450	0.250	0.35	6+ - 2
PB160	0.125	0.20	4+ - 2	PB500	0.250	0.40	6+ - 2
PB180	0.125	0.20	4+ - 2	PB560	0.30	0.50	6+ - 2
PB200	0.125	0.20	4+ - 2	PB630	0.30	0.55	6+ - 2
PB225	0.150	0.25	7+ - 3	PB710	0.30	0.60	7+ - 2
				PB800			
PB250	0.150	0.25	7+ - 3	PB900	0.35	0.70	7+ - 2
PB285	0.175	0.25	7+ - 3	>=	0.35	0.80	10+ - 3
				PB1000			

6. Fit Pins & Bushes & tighten nuts to recommended tightening torque.

7. The coupling should be shielded according to safety regulations. These shields/Guards should be made from wire mesh or perforated sheet if it is not in contradiction with other & prevailing requirements in order to ensure adequate ventilation of coupling.

8. It is advisable to recheck alignment and Nut tightness after few hours of initial operation. Retighten the bolts if necessary.

**3. MAINTENANCE-** Check Rubber bushes for wear & tear. If worn out/ loose, replace the same. Replace pins if necessary.